

Location Sensing in Ubiquitous Computing

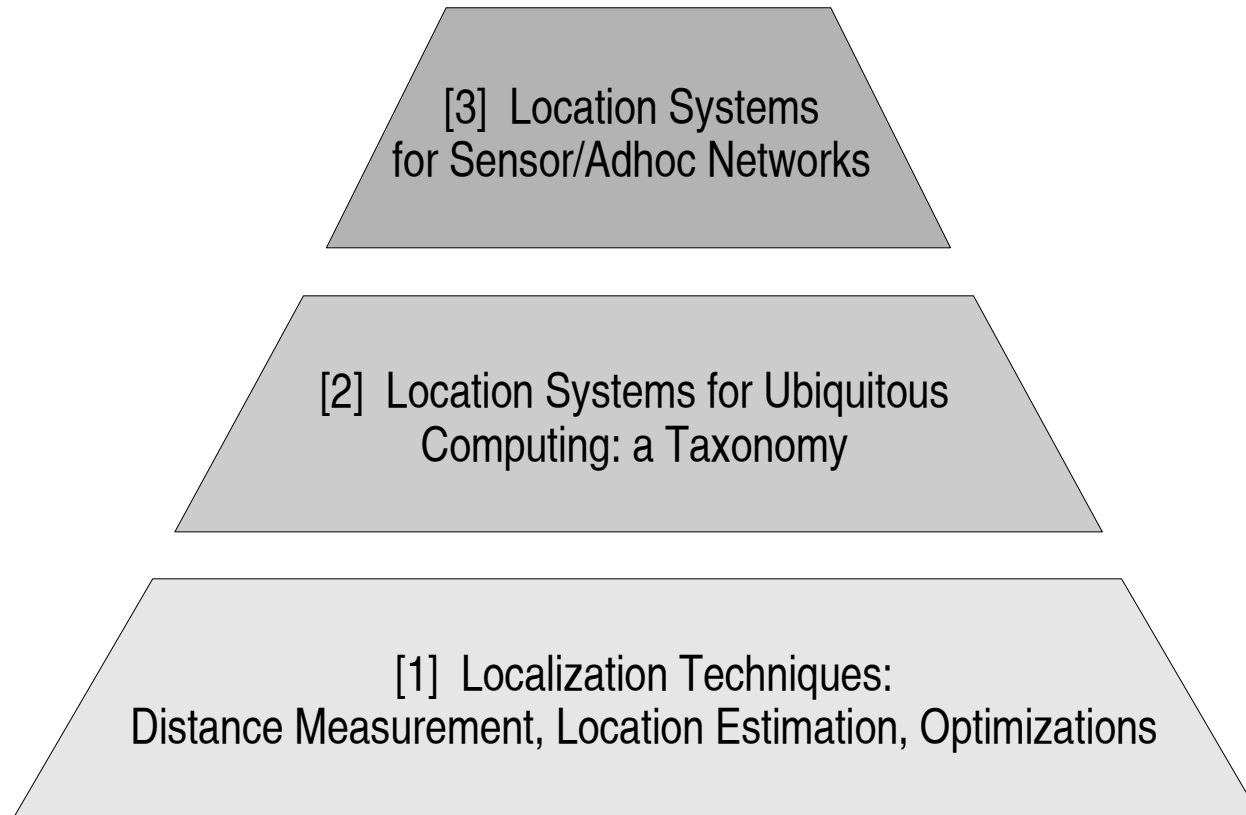

Localization steps

Range-based distance measurements:

- TOA / TDOA / AOA
- RSSI

Range-free distance measurement:

- Hop-Terrain
- DV-Hop
- Sum-Dist

Location estimation:

- Triangulation
- Trilateration
- Multilateration
- Min-Max
- Least-squares
- Proximity
- Scene analysis

Method optimizations:

- (incorporating the geographical or mobility model):
- sequential Monte Carlo
 - Markov modelling, Kalman filtering, Bayesian analysis

Phase 1: (Range-based) Distance measurement

- **Received Signal Strength Indicator (RSSI)** techniques measure the signal power at the receiver; knowing the transmission power and either the path loss model or the calibration map, loss is translated into distance or position
 - used for RF signals
- **Time-of-Arrival (ToA)** methods record the propagation time and, knowing the signal speed, translate it into distance
- **Time-Difference-of-Arrival (TDoA)** methods record the differences between the arrival of the same beacon at different sites; knowing the sites' positions, the sender's position can be inferred
- **Angle-of-Arrival (AoA)** methods read the angle of reception to a reference axis and, with the help of known distances, infer sender's position

Phase 2: Localization estimation techniques

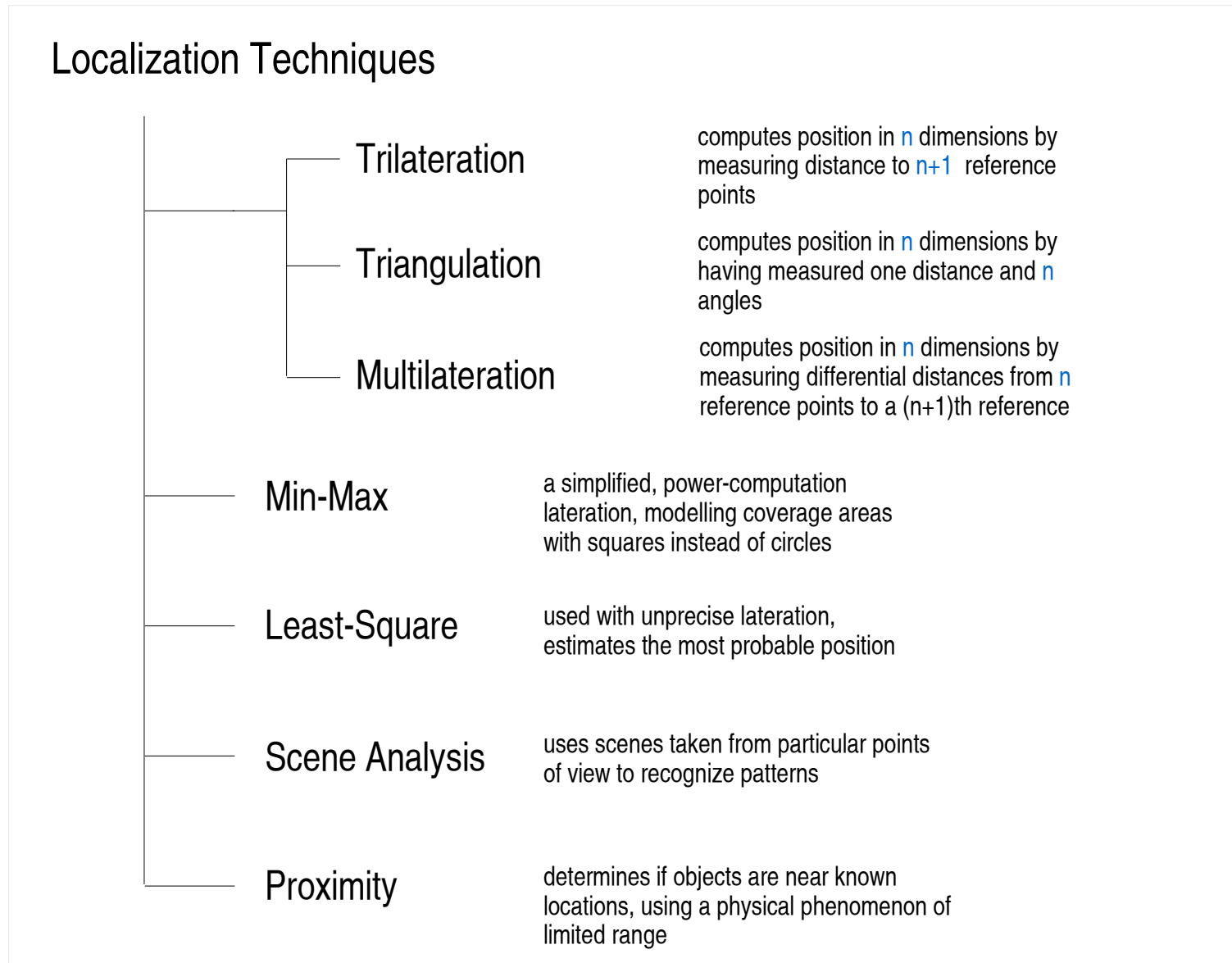

Trilateration

- Lateration needs (in theory) distance measurements from:
 - 3 non-collinear references to compute a 2D position
 - 4 non-coplanar references to compute a 3D position
- 2D example:

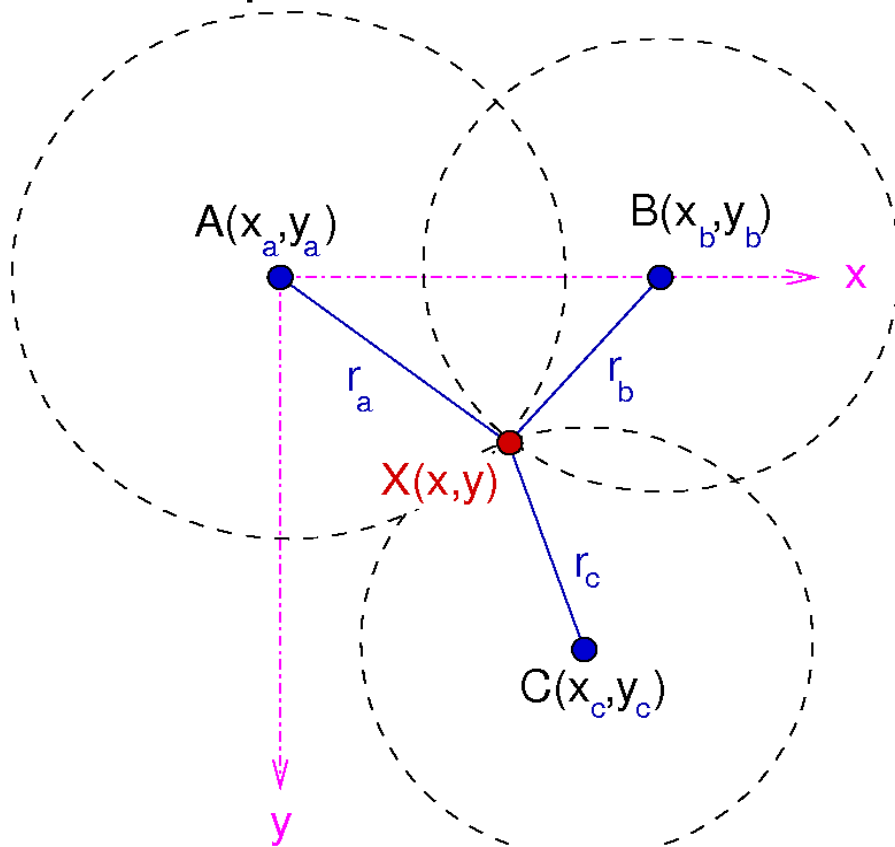

$$\begin{cases} x^2 + y^2 & = r_a^2 \\ (x - x_b)^2 + y^2 & = r_b^2 \\ (x - x_c)^2 + (y - y_c)^2 & = r_c^2 \end{cases}$$

$$x = \frac{x_b^2 + r_a^2 - r_b^2}{2x_b}$$

$$y = \frac{x_c^2 + y_c^2 + r_a^2 - r_c^2 - 2xx_c}{2y_c}$$

Trilateration (cont'ed)

- Empiric knowledge decrements the number of required measurements, if ambiguity of the last coordinate can be solved otherwise
 - 3D example (3 spheres instead of 4):

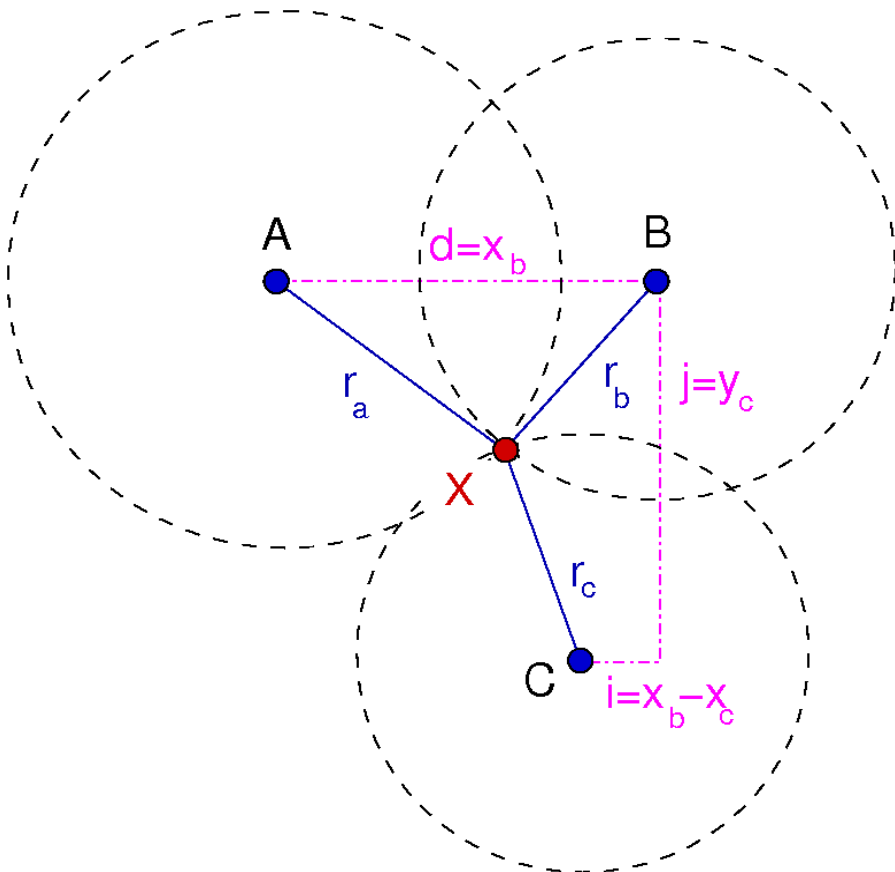

$$\begin{cases} x^2 + y^2 + z^2 & = r_a^2 \\ (x - d)^2 + y^2 + z^2 & = r_b^2 \\ (x - i)^2 + (y - y_c)^2 & = r_c^2 \end{cases}$$

$$x = \frac{d^2 + r_a^2 - r_b^2}{2d}$$

$$y = \frac{r_a^2 - r_c^2 + (x - i)^2}{2j} + \frac{j}{2} - \frac{(r_a^2 - r_b^2 + d^2)^2}{8d^2j}$$

$$z = \sqrt{r_a^2 - x^2 - y^2}$$

Triangulation

- Same as triangulation, only replacing some of the distance measurements with angle measurements
 - 2D example:

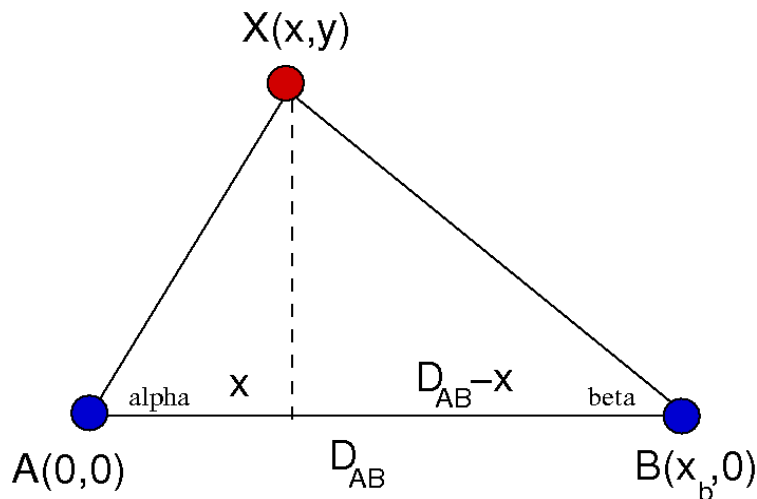

$$x = \frac{\tan \beta}{\tan \alpha + \tan \beta}$$

$$y = \frac{\tan \beta \cdot \tan \alpha}{\tan \alpha + \tan \beta}$$

Multilateration

- Same-beacon time difference of arrival from n references to a $(n+1)$ th reference gives nD position
- Knowledge of z can be had otherwise, reducing the number of references by 1
 - 3D example:
- Atomic vs. collaborative lateration

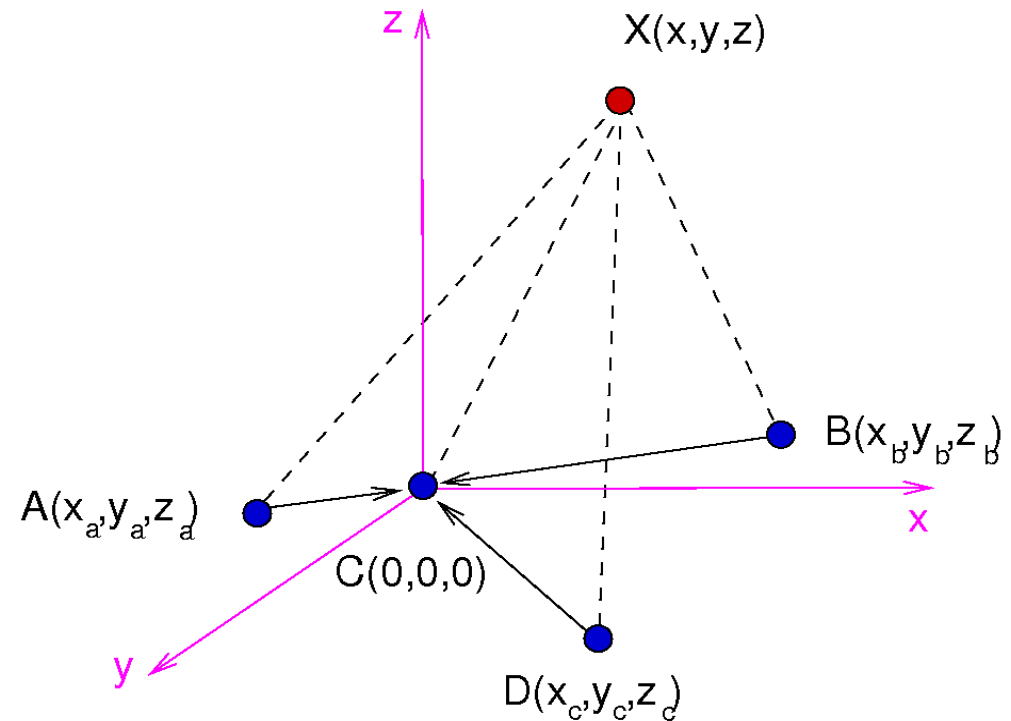

$$\tau_a = \frac{1}{c} \left(\sqrt{(x - x_a)^2 + (y - y_a)^2 + (z - z_a)^2} + D_{AC} - \sqrt{x^2 + y^2 + z^2} \right)$$

$$\tau_b = \frac{1}{c} \left(\sqrt{(x - x_b)^2 + (y - y_b)^2 + (z - z_b)^2} + D_{BC} - \sqrt{x^2 + y^2 + z^2} \right)$$

$$\tau_d = \frac{1}{c} \left(\sqrt{(x - x_d)^2 + (y - y_d)^2 + (z - z_d)^2} + D_{DC} - \sqrt{x^2 + y^2 + z^2} \right)$$

Min-Max

- Lateration is computation-heavy; a good simplification models around each anchor node a bounding box and estimates position at the intersection of boxes

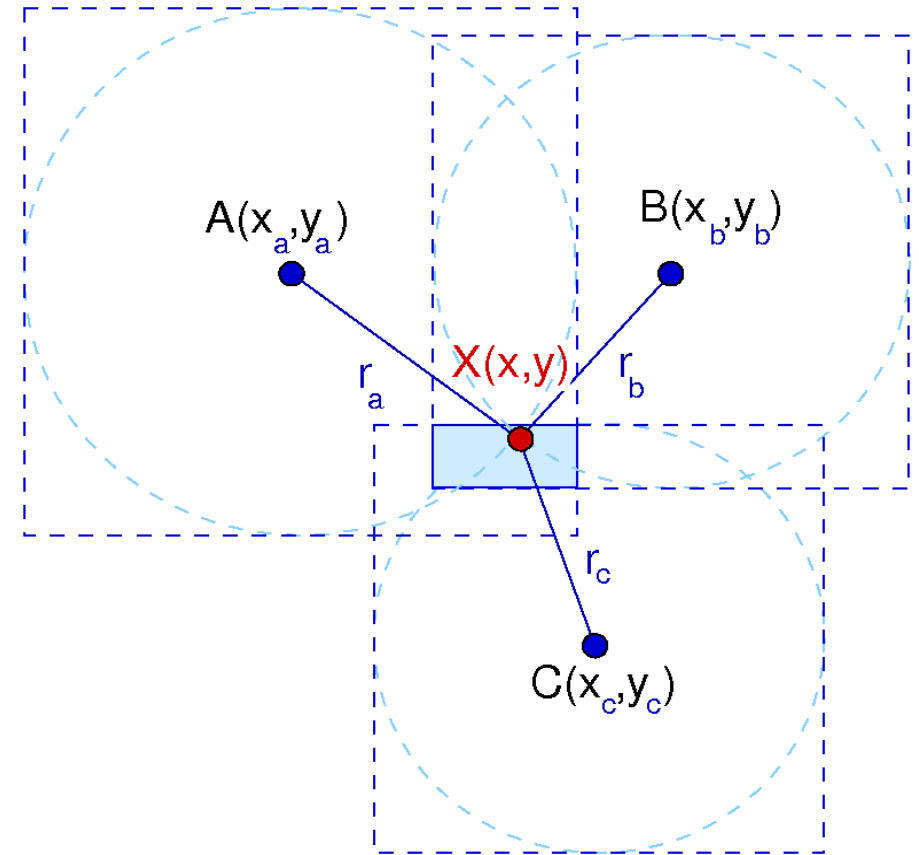

$$[\max(x_i - r_i), \max(y_i - r_i)] \times [\min(x_i + r_i), \min(y_i + r_i)]$$

Scene Analysis and Proximity

- **Scene analysis** uses features of a scene observed from a particular point of view to draw conclusions upon the (relative) position of objects. Differential analysis bases location on movement detection between frames
 - A scene can be a visual image or mapped electromagnetic characteristics
- **Proximity** location senses the presence of an object close to a certain point, using a physical phenomenon of limited range:
 - detecting physical contact (pressure sensors, touch sensors, capacitive field detectors) or ID security systems (points-of-sale, computer logins, telephone records)
 - monitoring roaming (access point associations)

Phase 3: Method optimizations

Uncertainty: when sensor observations only give a high bound or an interval for the true value, uncertainty is managed by computing the maximum-likelihood of the value (least-squares).

Mobility: a motion/still estimator helps localization by giving hints about the subject's speed

Bayesian filter techniques manage measurement uncertainty and sensor fusion for location estimation. They sequentially estimate beliefs over the state space considering new sensor data. Each new observation corrects the predicted belief.

$$Bel(x_t) = p(x_t | z_{1:t})$$

A 'belief' is the probability that the location is x if the history of the sensor measurements is $z [1:t]$

Kalman filters are Bayesian filters, assuming data distributions Gaussian.

Markov chains: a concrete localization method is helped by taking into consideration the exact range of possible movements

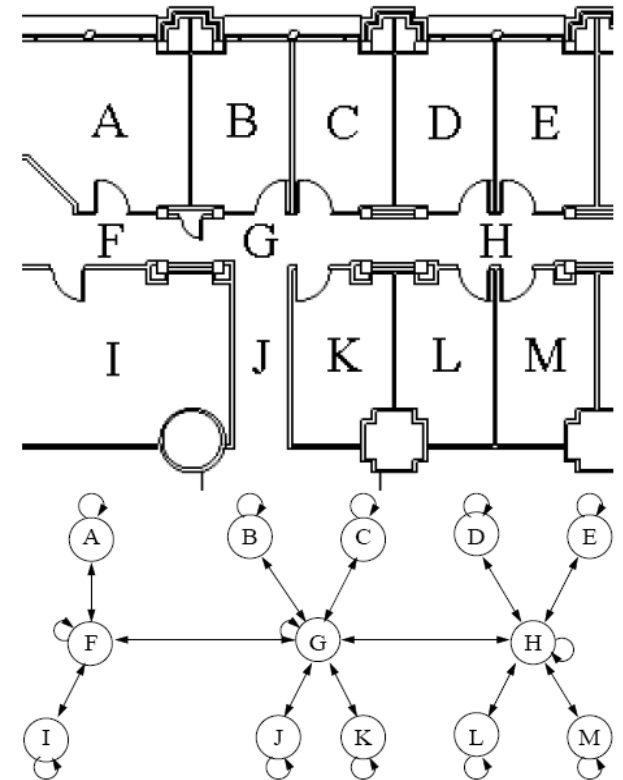

Taxonomy factors

Environment

Outdoor	wild / metropolitan environment; obstacles (if any) of large dimensions
Indoor	obstacle-based environment; prone to cell-grating and symbolic location

Distance measurement

Range-based	absolute positions into the system are computed from absolute distance measurements (RSSI, TOA, etc)
Range-free	relative positions are computed in a large network, to anchor nodes, or in terms of hop counts

Location estimation technique

Triangulation, Trilateration, Multilateration, Min-Max, Least-squares, Proximity, Scene analysis
--

Computation distribution

Centralized	location is determined at a single site, be it a client or an infrastructure
Distributed	location is inferred from aggregated input at various sites

Taxonomy factors (cont'ed)

Input signal

Electromagnetic	electromagnetic waves in different technologies (radio: narrow/wideband, IR, microwave), light, electromagnetic field, ultrasound
Mechanical	mechanical inertia, pressure

- Each signalling technology is chosen to serve a specific setting, depending on the physical properties of the wave (“sky waves” have longer range than microwaves)

- Localization range depends on wave frequency
- Localization error depends on
 - wave frequency (if transmission is narrow-band)
 - bandwidth (if wide-band)
 - multipath distortion

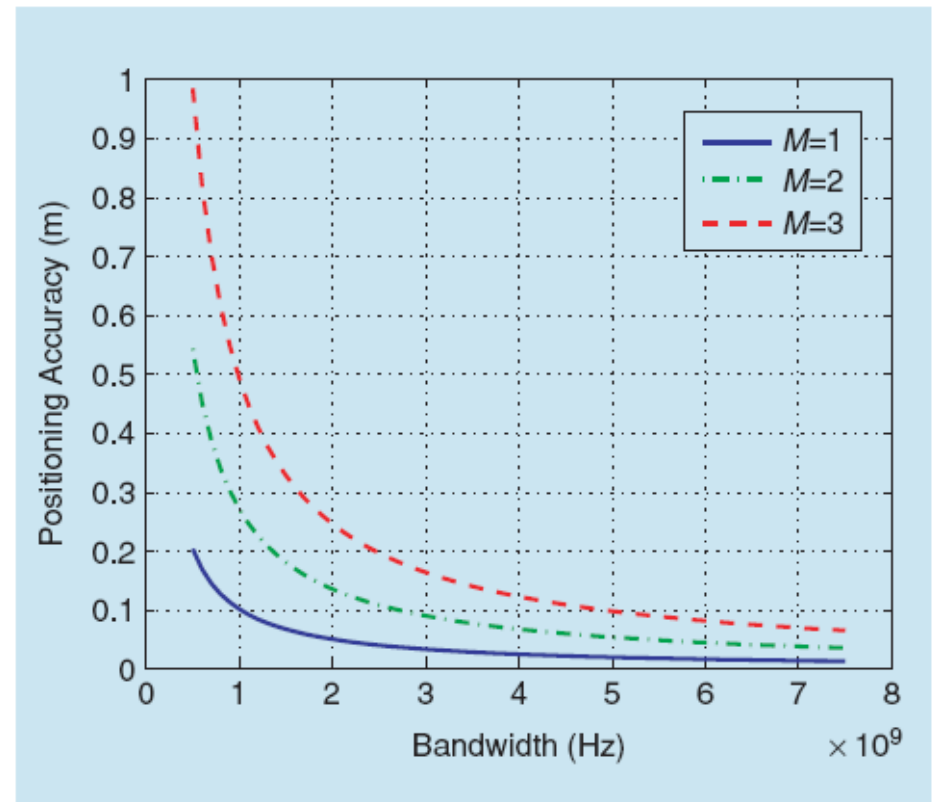

Taxonomy factors (cont'ed)

Position information

Physical position	[latitude, longitude, height] – coordinates relative to a large, flat coordinate system
Symbolic position	abstract positioning, relative to artificial reference points: in his car on the way home

- Supplementary information can be used to translate physical to symbolic locations and back (maps on a GPS client)
- Symbolic positioning is intendedly more coarse (and easier to compute) than physical positioning, but requires geographical information (maps)

Position frame of reference

Absolute position	the same location grid of reference is used for all located objects (lat/long, UTM); all locations can thus be compared
Relative position	each object is located within an own reference grid (relative to a moment's client)

- Supplementary information can be used to translate absolute to relative locations and back

Computation location

At client	for the client to compute its own location, the network emits telemetry
At infrastructure	for the infrastructure to compute the object's locations, the object must emit telemetry

- Computation location is strongly linked to system security: a client that computes its own location is location-wise secure

Taxonomy factors (cont'ed)

System performance

Accuracy	grain size, in units of distance, reached by a certain set of computation units
Precision	frequency (probability) of making a computation of a certain accuracy
Portability	the possibility of porting a location system to different sites without heavyweight calibration
Self-organization	the non-reliance on fixed infrastructure and ad-hoc fashion adaptation to random site conditions
Cost / Power consumption	cost of hardware, deployment, maintenance; power consumption, if the case
Scalability	Number of clients client weight per unit of infrastructure
	Geographical distance physical range an infrastructure can be extended to cover
Privacy	

- There is a trade-off between precision and accuracy
- Accuracy is greatly tailored to the specific application (room-sized, in 0.5m squares) and it is limited by the physical properties of signal input
- Both scale limits are determined either by physical limitations of the communication method (channel congestion, radio range) or middleware complexity

Location sensing in UbiComp – a taxonomy

	Environment	Input signal	Distance measurement	Location estimation	Position info & reference	Computation location	System performance: accuracy & precision, calibration, adhoc, power, scalability, privacy features
GPS 1978	outdoor	radio, 1176.45 Mhz - 1841.40 MHz	range-based ToA	trilateration to 4 satellites for 3 axes and time	physical, absolute	at client	2m; 1cm with Differential GPS
Active Badges 1992	indoor	infrared	range-based proximity	diffuse infrared cellular proximity of badge to room base	symbolical, absolute	at infrastructure	room size; scale: 1 base / room, 1 badge / base x10s; high interference risk
Active Bats 1994	indoor	ultrasound	range-based ToA	lateration	physical, absolute	at infrastructure	3D position, 9cm @95%; scale: 1 base / 10sqm, 10 computations / room x1s; heavy ceiling sensor grid infrastructure
Cricket 2000	indoor	radio and ultrasound	range-based proximity and TDoA	proximity and lateration of base beacons	symbolic, absolute or relative	at client	4x4 feet regions @ 100%; 1 beacon base / 16 sq feet
RADAR 2000	indoor	radio, 802.11	range-based proximity and RSSI	scene analysis and triangulation of RSSIs from WLAN bases	physical, absolute	at infrastructure	3-4.3m @50%; WLAN installation required, 3 bases / floor
Easy Living 2000	indoor	radio and ultrasound	geometrical analysis	scene analysis	symbolic, absolute	at infrastructure	3 cameras / room, not scalable processing power and privacy issues
Smart Floor 2000	indoor	physical contact (proximity); pressure	proximity	scene analysis	physical, absolute	at infrastructure	the distance between pressure sensors @ 100%; complete sensor grid / floor calibration for foot training dataset; does not scale to many subjects

Location sensing in UbiComp – a taxonomy

	Environment	Input signal	Distance measurement	Location estimation	Position info & reference	Computation location	System performance: accuracy & precision, calibration, adhoc, power, scalability, privacy features
SpotOn 2000	indoor	radio	range-based RSSI to special tags	adhoc lateration to estimate distance between tags	physical, relative	at infrastructure	<ul style="list-style-type: none"> • depends on cluster size and density; • RSSI less accurate than ToA
E911 [only a FCC requirement]	outdoor	cellular radio	-	-	physical, absolute	at infrastructure	<ul style="list-style-type: none"> • 150-300m @ 95% • only where cell coverage exists • scales to the density of cellular infrastructure
Ekahau 200x	indoor	radio, 802.11	N/A	N/A	symbolic, absolute	at infrastructure	<ul style="list-style-type: none"> • tags require no additional WLAN hardware overlay; • can 3D track laptops, PDAs, tags; • single server; • requires site calibration; • up to 1-meter accuracy (indoors, 3+ access points in range)
LANDMARC 2004	indoor	RFID radio	proximity and RSSI from tags to reference tags	euclidean RSSI distance gives the closest reference (nearest neighbour)	physical, absolute	at infrastructure	<ul style="list-style-type: none"> • RSSI not available, but computes through power level scanning; • at 1 reference / 1cubm, accuracy is 1m • not scalable nor accurate
UBISENSE 2004	indoor	UWB channel: 5.8-7.2GHz plus control channels	TDoA between infr. sensors; AoA	lateration+ angulation	physical, absolute	at infrastructure	<ul style="list-style-type: none"> • 6 inches in 3D; • UWB is NLOS and overcomes radio multipath interference, infrared range and LOS; • sensor-to-tag range: 50m

Ubisense

- The network consists of Ubisensors that are fixed in known positions and networked using standard Ethernet. Each Ubisensor has a conventional RF transceiver and an array of UWB receivers. Ubisensors are organized into cells of 4 to 7.
- The located objects are tagged with Ubitags. Each Ubitag has a conventional RF transceiver and a UWB transmitter.
- Each cell has one Ubisensor that acts as master. It coordinates the TDMA network using the RF channel, so that each Ubitag is allocated a schedule of slots.

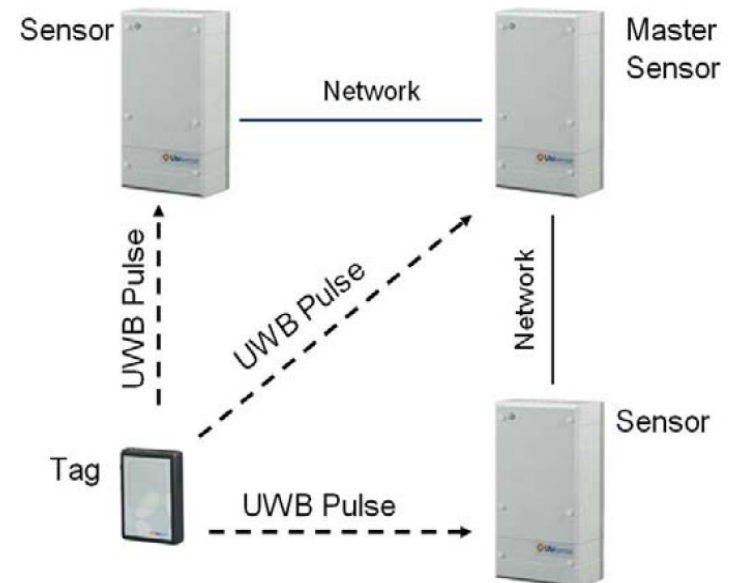

Ubisense (cont'ed)

- When a Ubitag is active, it sends a RF message with its identity, together with a UWB pulse sequence.
- Ubisensors use a combination of TDoA and AoA to determine the location of the Ubitag.
- Only two Ubisensor readings are required to generate a 3D position for a tag.
- A timeslot is about 26ms, leading to a maximum update rate per cell of about 39Hz, with each Ubitag having a maximum update rate of 10Hz. In a typical open environment, a location accuracy of about 15cm can be achieved across 95% of readings.

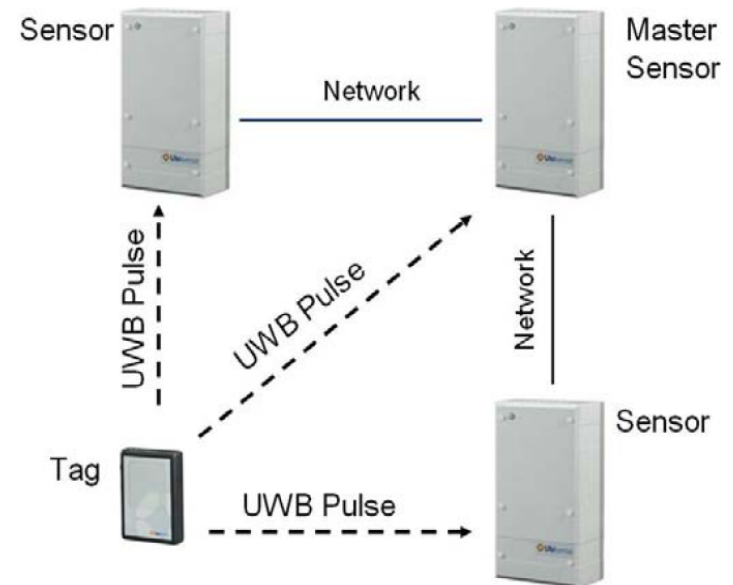

New directions and formalisms

- **Sensor fusion**: since each ranging method has shortcomings, combining readings from different types of sensors with different capabilities and error profiles will exploit redundancies and contradictions to reduce location uncertainty. (ex.: adding inertial input to any location system)
- **Software support**: in the search for a common software architecture and interface set, a case is Hightower's 7 layer Location Stack

Design Principles:

5. Applications are usually concerned with **activities**. The reason for capturing location and other context data is typically not for direct use in applications but to enable reasoning at the level of user activities.

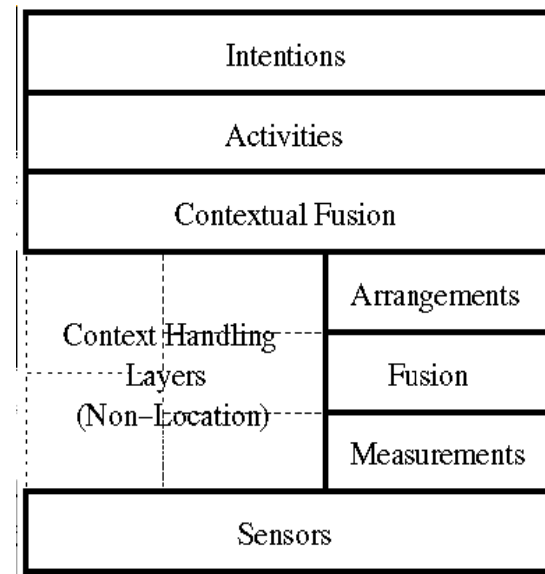

Localization in adhoc networks

- Localization algorithms for sensor networks should be self organizing, adaptive and energy-efficient
 - **Centralized** localization depends on sensors sending data to a central computation location – might be infeasible for mobile applications
 - **Distributed/adhoc** localization has nodes communicating with neighbour nodes
 - range-free localization is more power-efficient

- **Range-free localization methods:**

Local techniques that rely on a good density of anchor nodes in vicinity:

Centroid method: a node estimates its location by calculating the geographical center of all seeds it hears

APIT method: breaks the area into seed triangles

Hop-counting algorithms – if seed density is low, location adverts are propagated through the multihop network:

DV-HOP (or Hop-TERRAIN) uses DV routing (seed locations are advertised) to maintain a hop-based routing table to seeds

Distributed adhoc localization: APS (2001)

- Ad Hoc Positioning System (APS)
 - Uses a set of landmark nodes (3, to compute a position in a plane)
 - Landmarks emit beacons, so that, starting with immediate neighbour nodes, all nodes can eventually read their distance to landmarks, in hops
 - Hop-to-hop distance propagation can be classical DV-Hop (the metric is hops), DV-Distance (RSSI to meters) or a node estimates its position by as an Euclidean distance to a landmark L, if distances from 2 neighbours A and B (L_A , L_B) are known

Distributed adhoc localization: AHLoS (2001)

- Ad Hoc Localization of Sensors

- Beacon nodes and unknown nodes; beacon nodes broadcast their position, and, in turn, unknown nodes become beacon nodes
- Estimation is done as iterative lateration (atomic lateration, performed when 3 beacon nodes are in sight)
- Sees (multihop) collaborative lateration as an optimization
- Tested, for RF and ultrasound ToA (Medusa motes) and lower-performance RF RSSI with a path loss model (WINS motes)

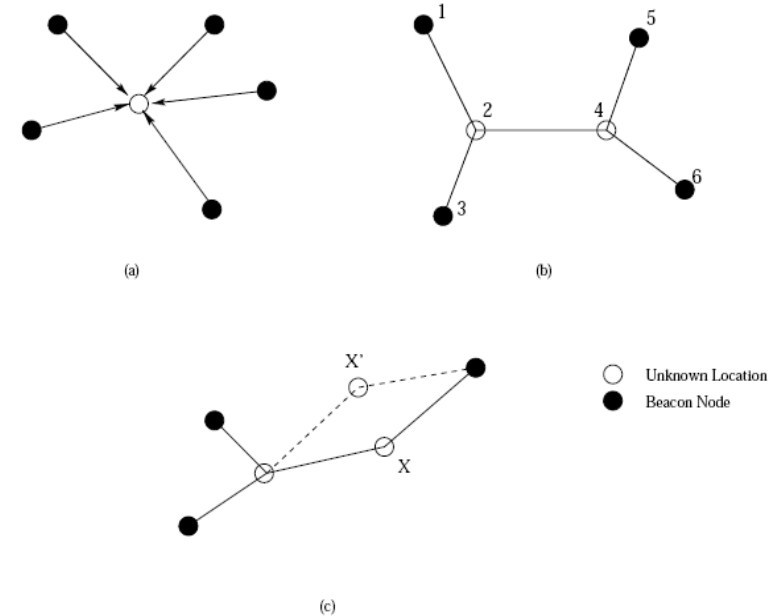

Location-aware adhoc routing protocols

- Approaches to exploit location information in the routing of a manet
 - Traditional routing protocols (DSR, ZRP, AODV) flood packets in zones of or the entire manet

Location-aided routing (LAR): instead of flooding unaware zones, LAR defines a smaller forwarding zone to cover the source and destination

The location-aided routing (LAR) protocol uses selective flooding to search for routes. Forwarding zone optimizations confine the route-searching area: (a) rectangle, (b) bar W , (c) fan, and (d) dual fan; r and θ are tunable parameters.

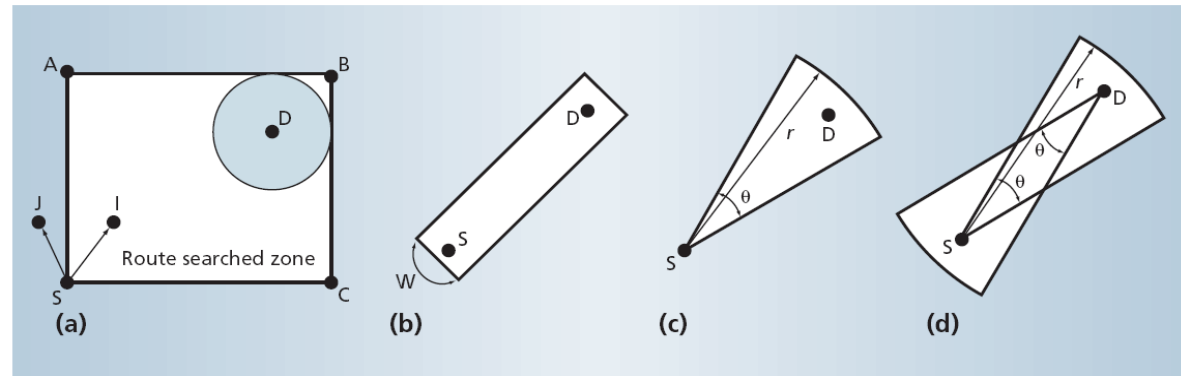

Geographic distance routing (GeDir): X forwards to Y, where $[XY]$ has the smallest angle to $[XD]$, or where Y is closest to D

Grid: partitions the area in squares, in which only leaders perform routing

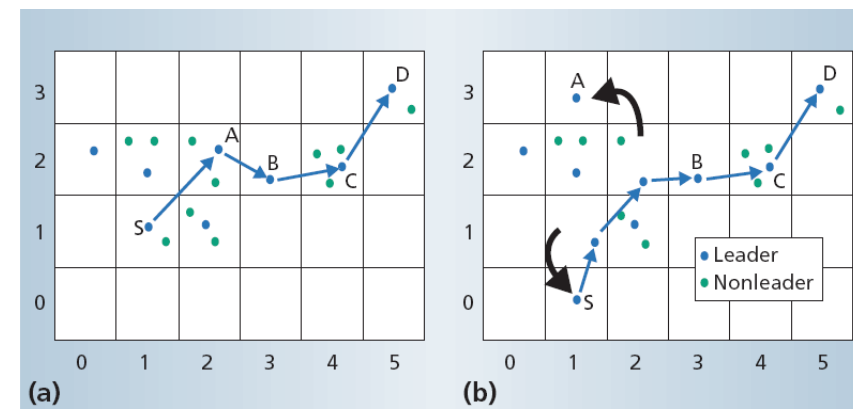

A routing example in the Grid protocol. (a) Routing tables offer stronger, more resilient route maintenance because they use grid IDs to represent a packet-relay route. (b) Route maintenance is highly resilient to host mobility because the system elects a new leader when the current leader roams out of the defined grid.

MoteTrack

- First decentralized location system; the site needs calibration and the beacon signature database is replicated on nodes; based on RSSI
- Mica2 motes; some motes are used as *beacons*, broadcasting periodical beacon messages
- Each nodes acquires *signatures* (collections of beacons); *reference signatures* are signatures for known locations (gathered by calibration)
- The location is estimated at the centroid of the set of reference signatures that are within some ratio of the closest reference signature to this node's acquired signature
- The closest beacon node will be asked to do the estimation (it is supposed to have in database the right reference signatures)

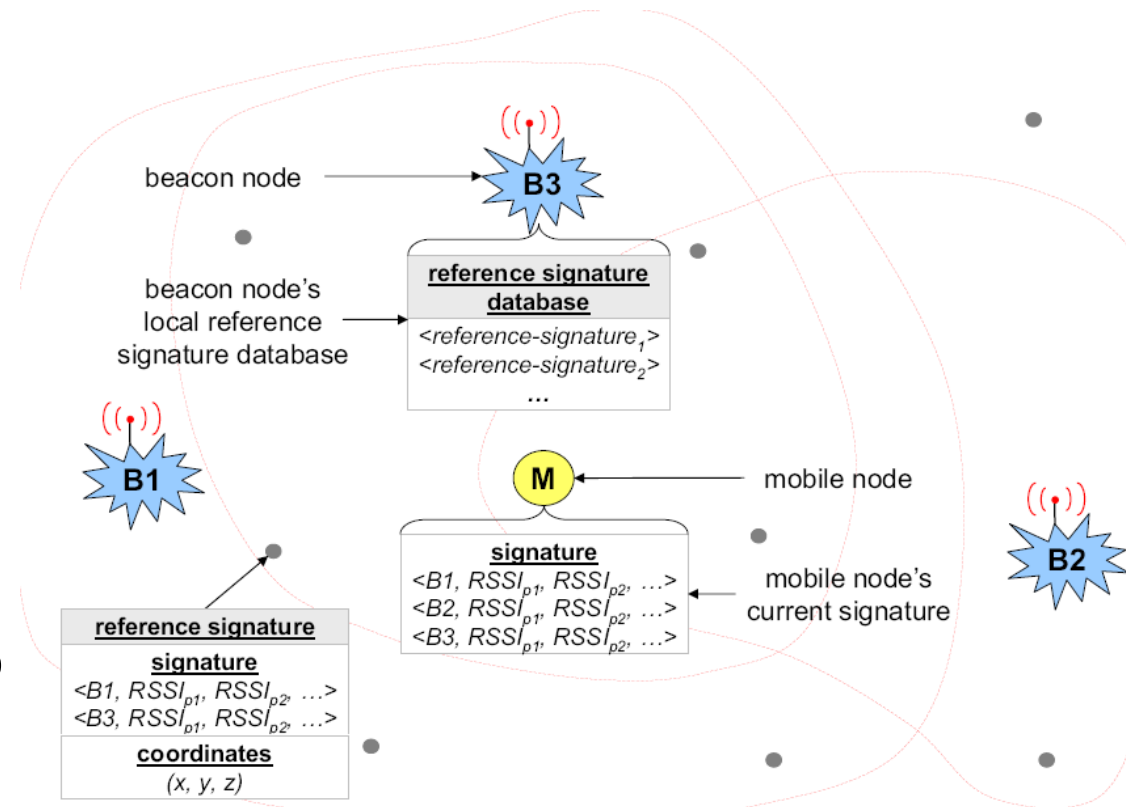

Chipcon's Radiolocation Hardware Core

- Location-on-radio-chip; node-to-node RSSI measurements are used in a joint estimation (collaborative lateration) together with the seeds' locations; computation on the node

Step 1: Each node collects RSS data from all links that it establishes. This step is similar for both centralized and distributed radiolocation.

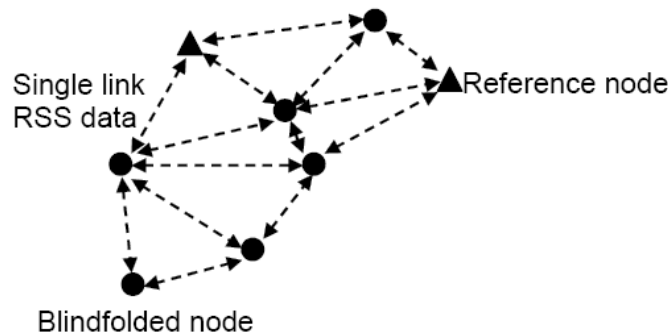

- RSSI readings come passively from data exchanges
- the estimation uses all the RSSI data in the network, even between blind nodes
- the estimation is distributed, and estimates are exchanged in neighbourhoods

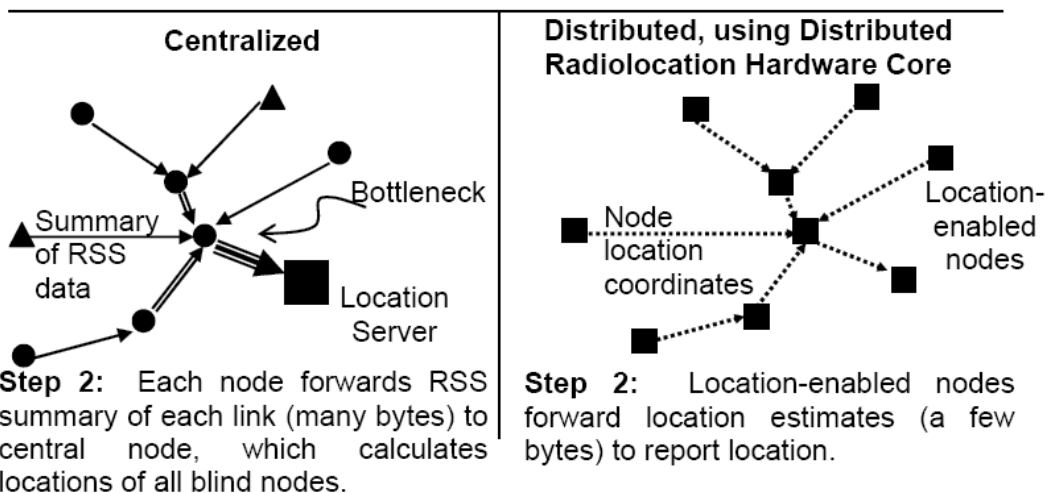

Area size: 64 x 64 m; Reference nodes used: 3 to 8; Accuracy: typically better than 3 m



CC2431 Kits

CC2431ZDK ZigBee Development Kit Pro

USD \$10 700,00

CC2431DK Development Kit

USD \$995,00