



<http://www.itesm.mx>

# An Expressive Coloured Petri Nets Methodology Applied to a Business to Business Environment

Fernando Ramos ([framos@campus.mor.itesm.mx](mailto:framos@campus.mor.itesm.mx))

Juan Frausto ([jfrausto@campus.mor.itesm.mx](mailto:jfrausto@campus.mor.itesm.mx))

Francisco Camargo ([fcamargo@campus.cem.itesm.mx](mailto:fcamargo@campus.cem.itesm.mx))

MOCA'01, Workshop on Modelling of Objects, Components, and Agents,  
August 28, 2001

# Agenda

- A definition of Cooperative Information Systems and their problematic
- Research objective
- The main contributions:
  - The improvement of the expressiveness for modelling interaction using Coloured Petri Nets (CPN)
  - IMCIS: Interaction Methodology for Modelling Cooperative Information Systems (CIS)
- An Application of IMCIS
- Conclusion and future work

# Cooperative Information System (CIS)

- It is a Cooperative Multi-Agent System integrating data and procedures, working in a cooperative way, by exchanging information, to achieve a common goal.

# General Framework of the Cooperative Information System

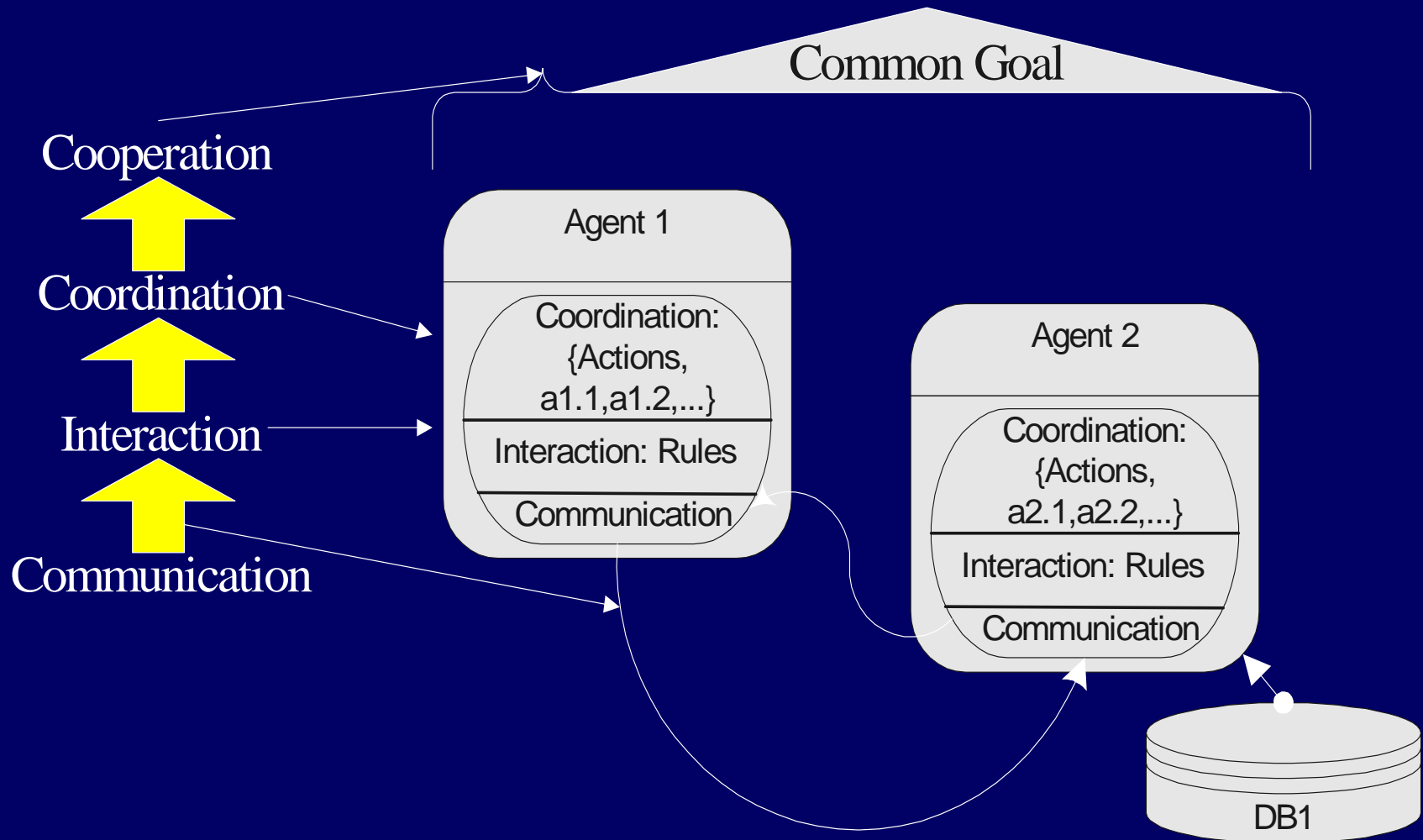

# The Problematic of Cooperative Information Systems

- CIS are dynamic by nature.
- Complex to model:
  - ambiguity and control.
- Complexity increases due to multiple interactions

# Related works

- The First Order Logic [Haddadi, 1998].  
(Hard to manipulate for the Software Engineer users).
- State Transition Diagrams [Cohen and Levesque, 1995; Flores and Winograd, 1986].  
(The representation increases exponentially in multiple interactions; it is not an expressive tool).
- Condition/Event (C/E) Petri Nets [Demazeau et al, 1998].  
(Applicable in interactions by pairs, and the representation becomes complex in multiple interactions; it is not an expressive tool).

# Research Objective

- To develop a methodology to model interactions in CIS by considering:
  - Expressiveness.
  - The skill to handle multiple simultaneously interactions.
  - A formal approach.
  - Adaptability to several domain of applications.

# Coloured Petri Nets

- A Petri Net is:
  - A formal and graphic modelling language,
  - Adequate for modelling complex systems with concurrency.
- A Coloured Petri Net (CPN) is:
  - A high level Petri net,
  - Where the colour of the token represents arbitrary data values.

[Jensen, 1997]

# Modelling Interaction With Condition / Event (C/E) Petri Nets [Demazeau et al., 1998]

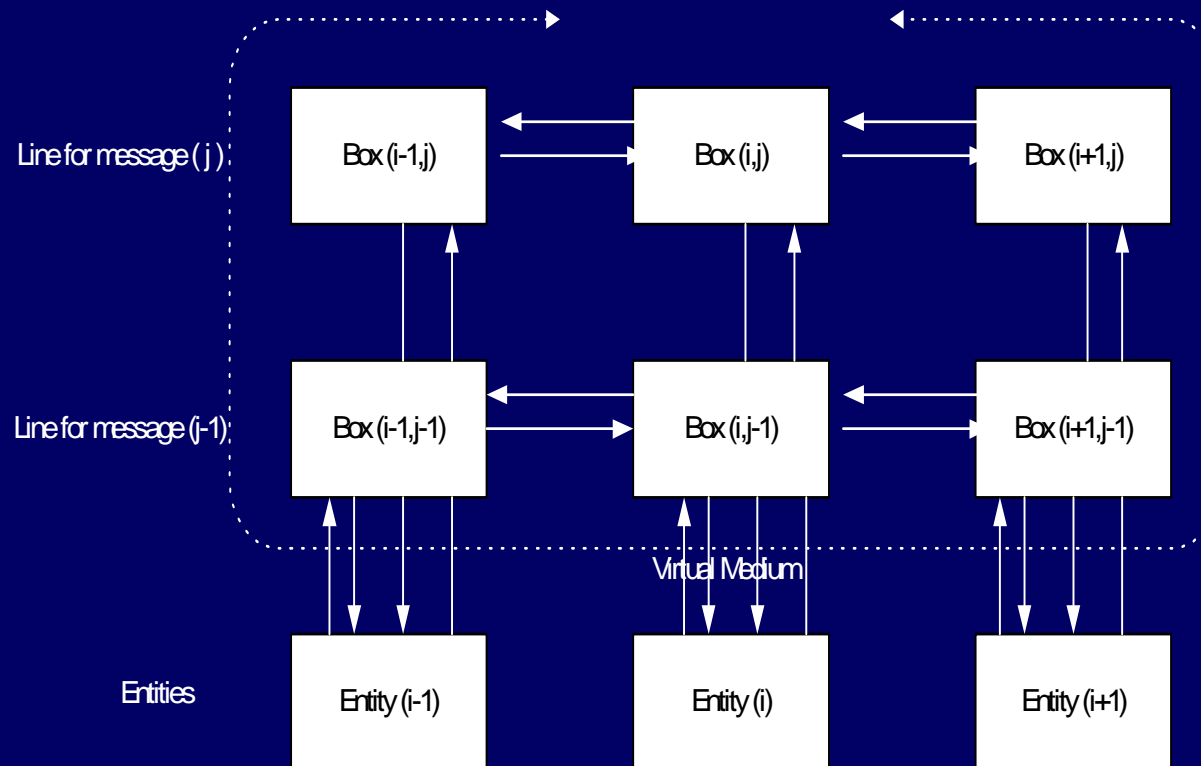

- Complexity:  $O(m^2 * n)$
- Complexity of modelling a new simultaneous interaction:  $O(m^2 * s)$

Complexity in terms of the number of links between agents interactions.

$m$ : message numbers.

$n$ : systems agents.

$s$ : number of additional agents participating in the interaction.

# Our Proposal: Modelling Interaction With Coloured Petri Nets (CPN)

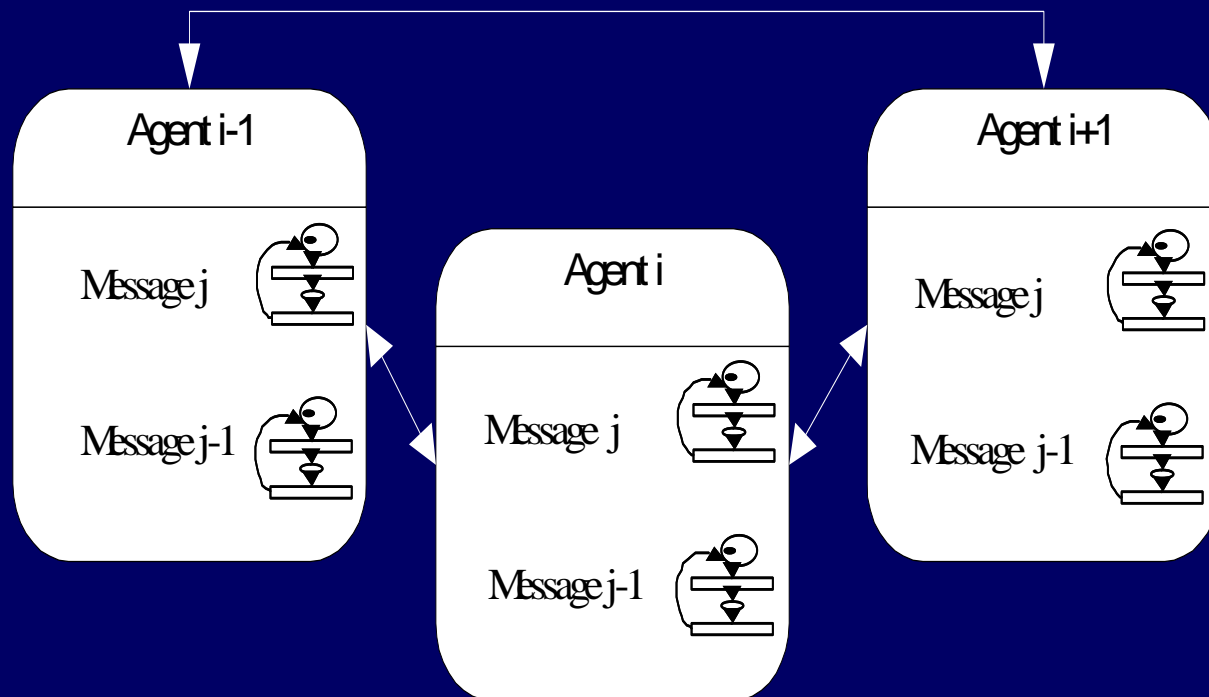

- Complexity:  $O(n^2)$
- Complexity of modelling a new simultaneous interaction:  $O(n*s)$

Complexity in terms of the number of links between agents interactions.

$m$ : message numbers.

$n$ : systems agents.

$s$ : number of additional agents participating in the interaction.

# Modelling Interaction in CIS

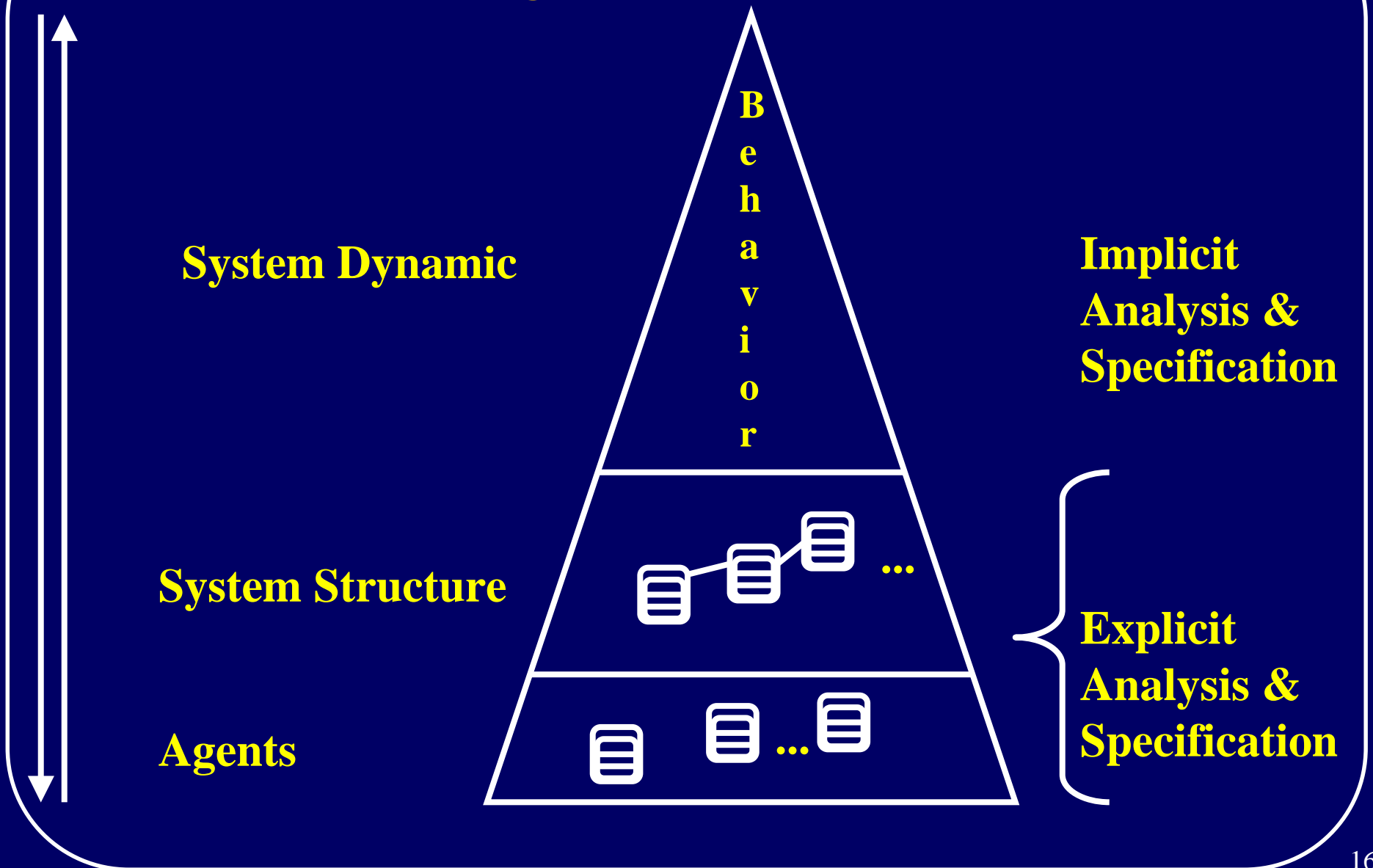

# IMCIS: Interaction Methodology for Modelling Cooperative Information Systems

- Explicit Analysis and Specification:
  - To identify agents and their intentions (**individual model**).
  - To build the agents diagram (**structural model**).
  - To build the interaction diagrams (**structural model**).
  - To design the agent ports (**structural model**).
  - To design the messages (**structural model**).
  - To specify the systems messages using Coloured Petri Nets (**structural model**).
- Implicit Analysis and Specification:
  - To simulate the system interactions (**dynamic model**).

## An Application of IMCIS

- A business to business (B2B) with buyers, suppliers and the marketplace.

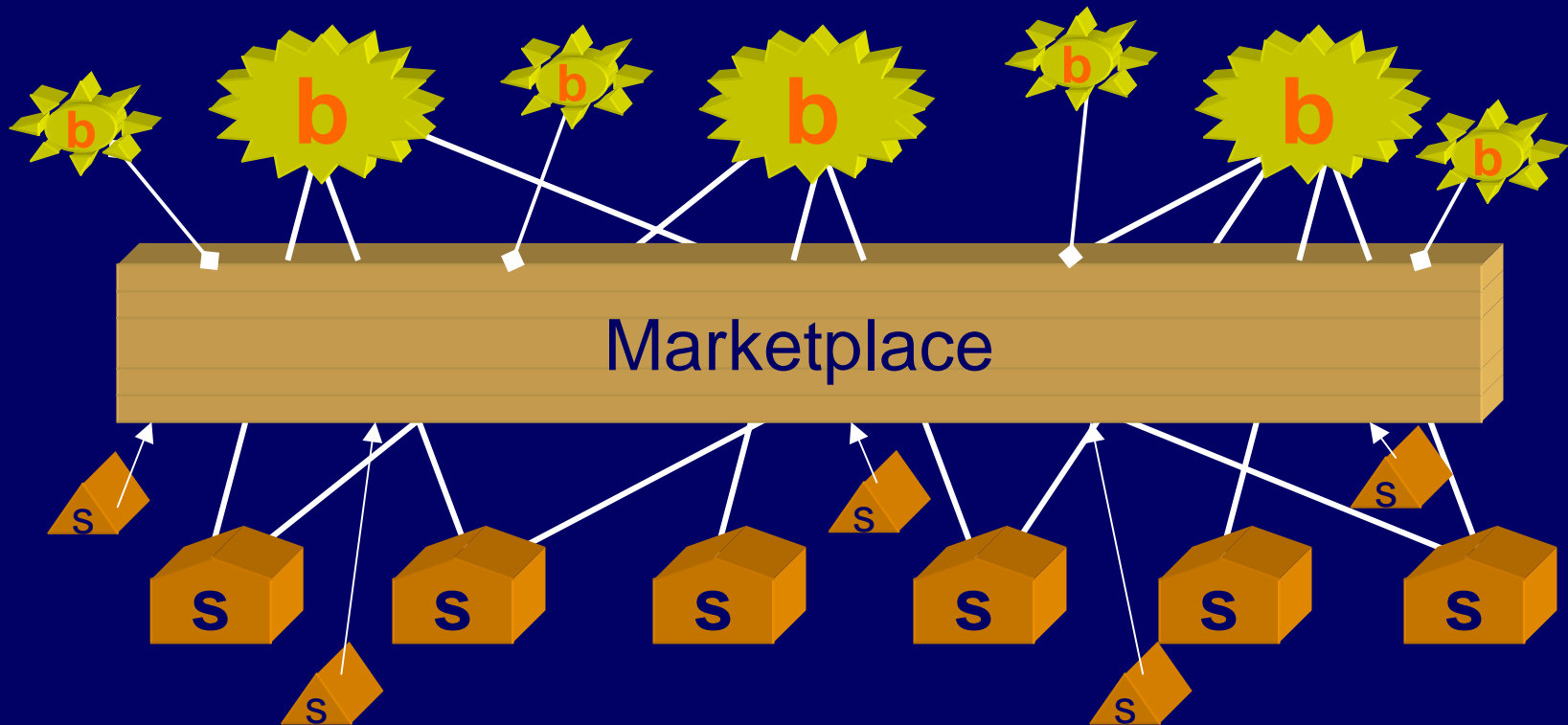

## Specifying the CIS

- $CIS = \{A, Cg, Gk, I\}$ :
- *A: Agent Set*,
  - $A = \{(\text{Buyer, best buying}),$
  - $(\text{Marketplace, effective relationships}),$
  - $(\text{Supplier, best offer})\}$ .
- *Cg : Common Goal*,
  - best offer,
  - best agreements with suppliers.
- *Gk: Global Knowledge*,
  - $Gk = \{\text{Buyer needs, products, agreements}\}$ .
- *Interaction Set*,  $I = \{\text{B2B Transaction}\}$

# Interaction Modelling with the Action Basic Loop

## System Interactions Analysis

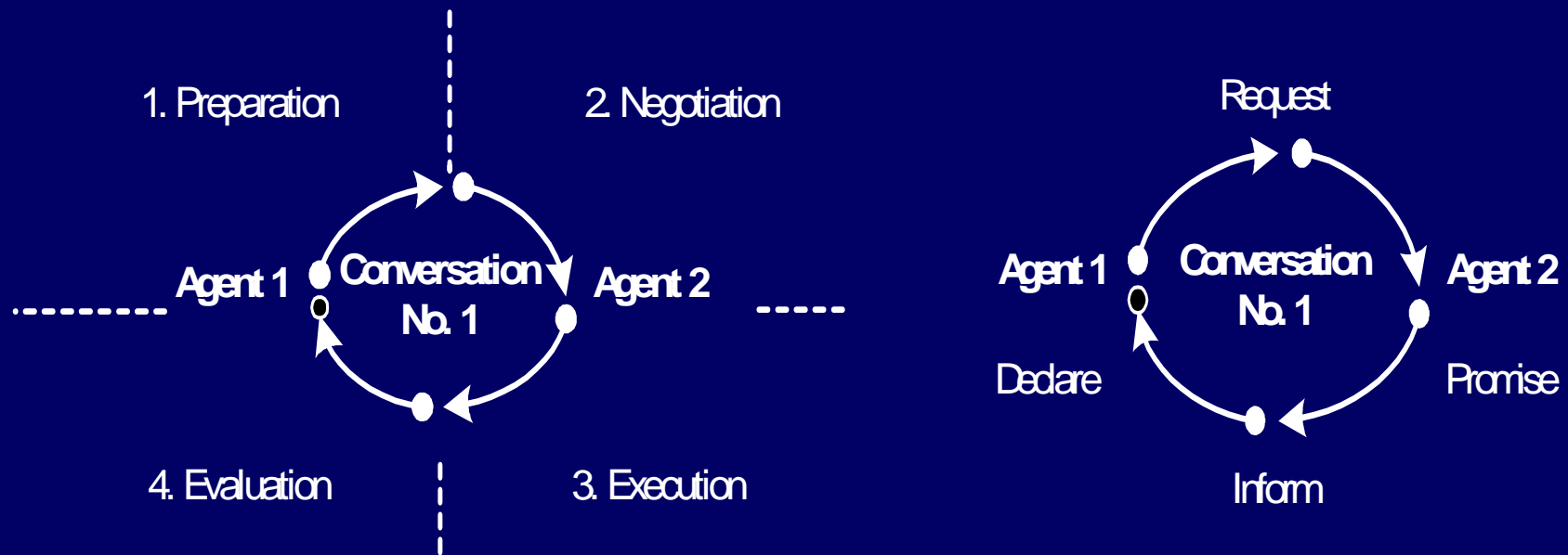

Action Basic Loop [Flores, 1996]

# Interaction Diagram

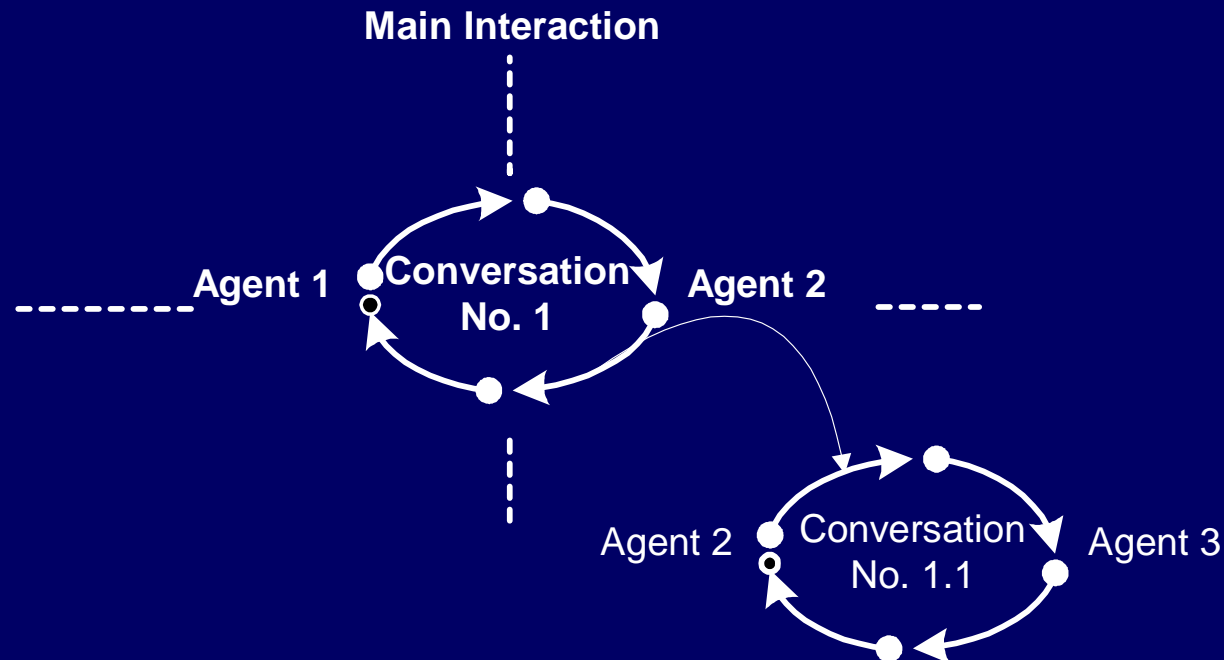

- Many conversations are part of an interaction.
- The basic action loop helps us:
  - To have a coordinate conversation between agents
  - To join more than two agents simultaneously in the coordinate conversation, building an Interaction

# Building the Interaction Diagrams

Interaction: B2B Transaction

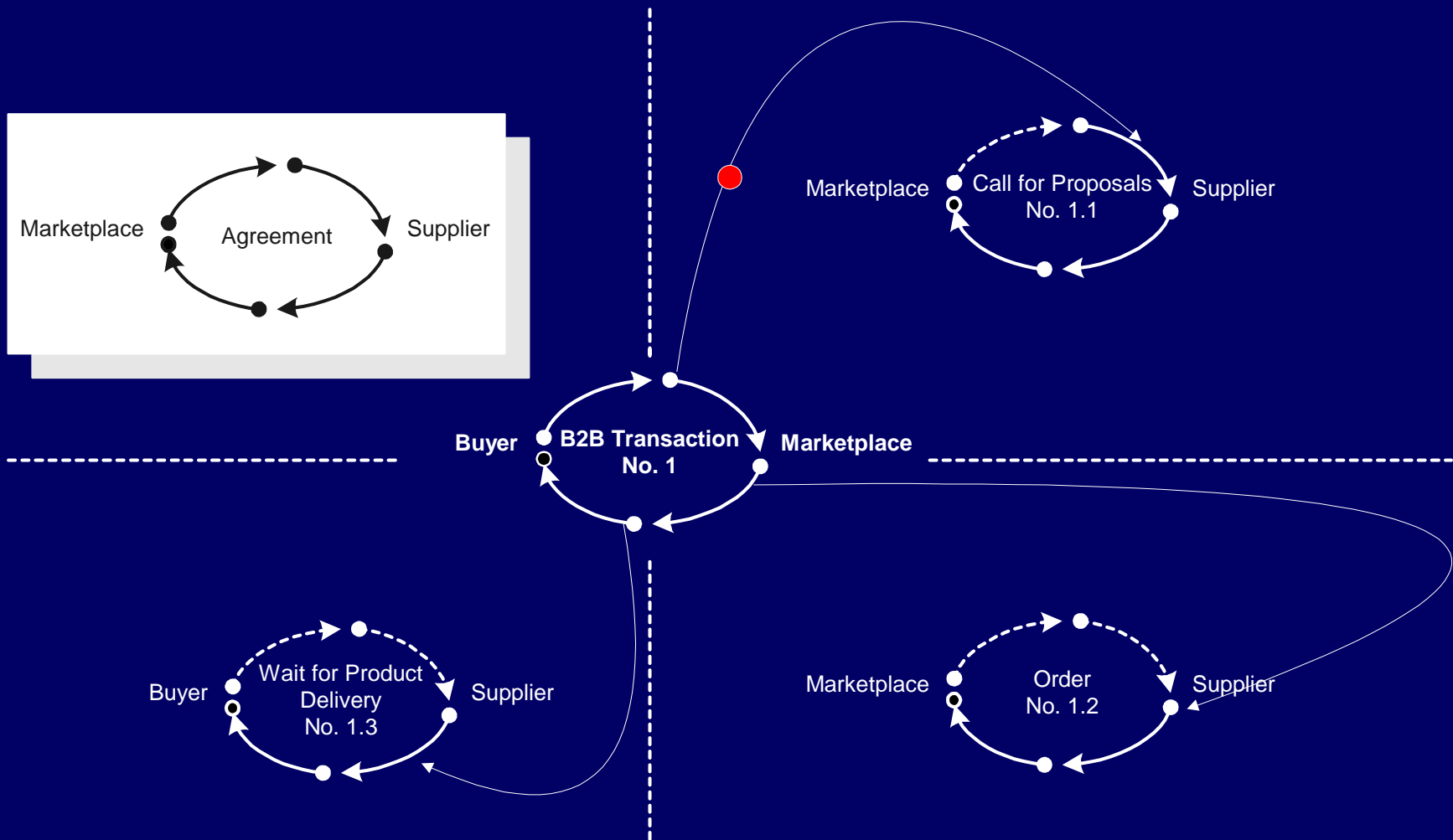

# Designing the Agent Ports

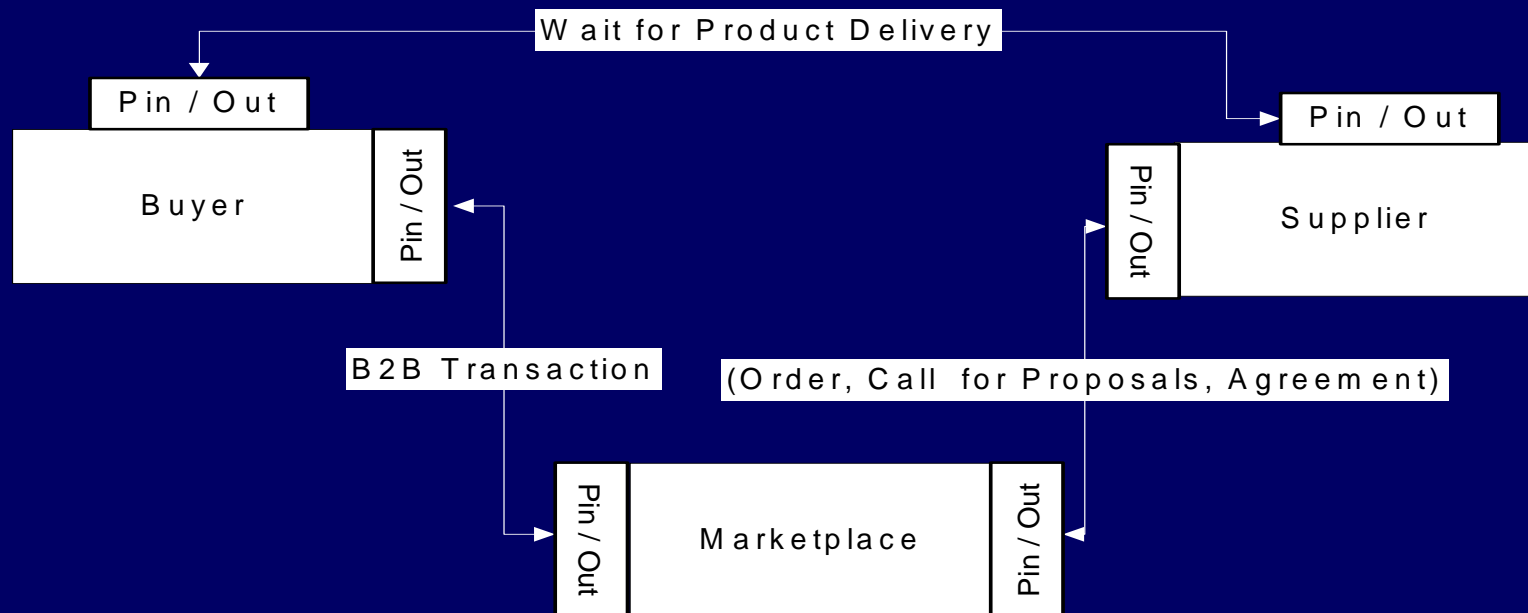

- **Buyer.Pin** <sub>B2B Transaction</sub>, **Marketplace** (Agree, Decline, Counteroffer, Report Completion(Type), Revoke(Type), Revoke and Counteroffer, Close(Type), Ask Recons(Type)).
- **Buyer.Pout** <sub>B2B Transaction</sub>, **Marketplace** (Request, Declare Satisfaction(Type), Cancel(Type), Cancel Make New Request, Decline to Accept(Type), Close(Type), Ask Recons(Type), Counter, Decline Counteroffer, Agree to Counteroffer).

# CPN for the Basic Action Loop

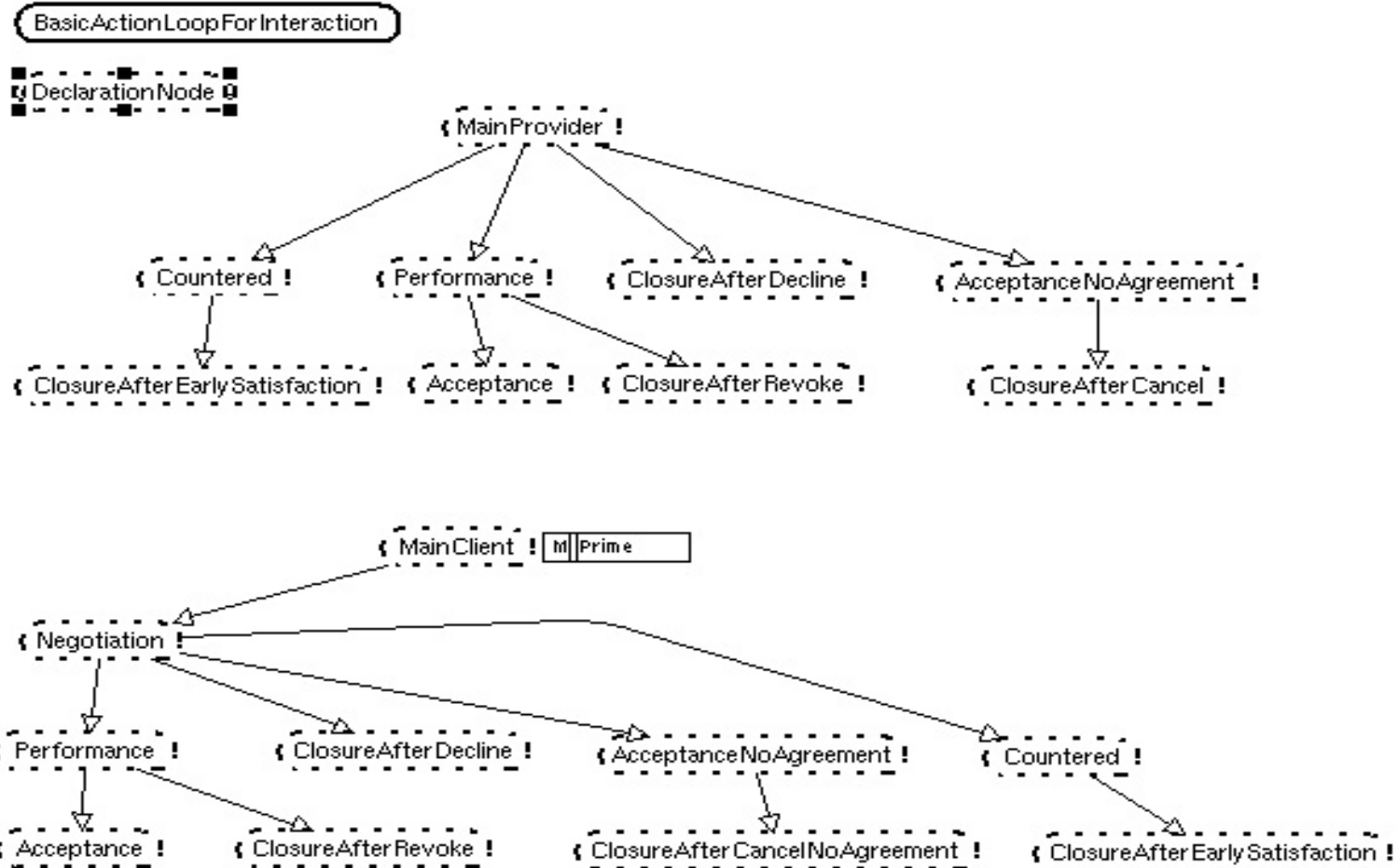

# Preparation Step

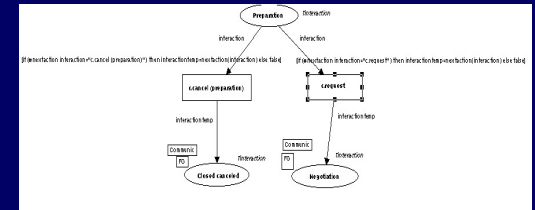
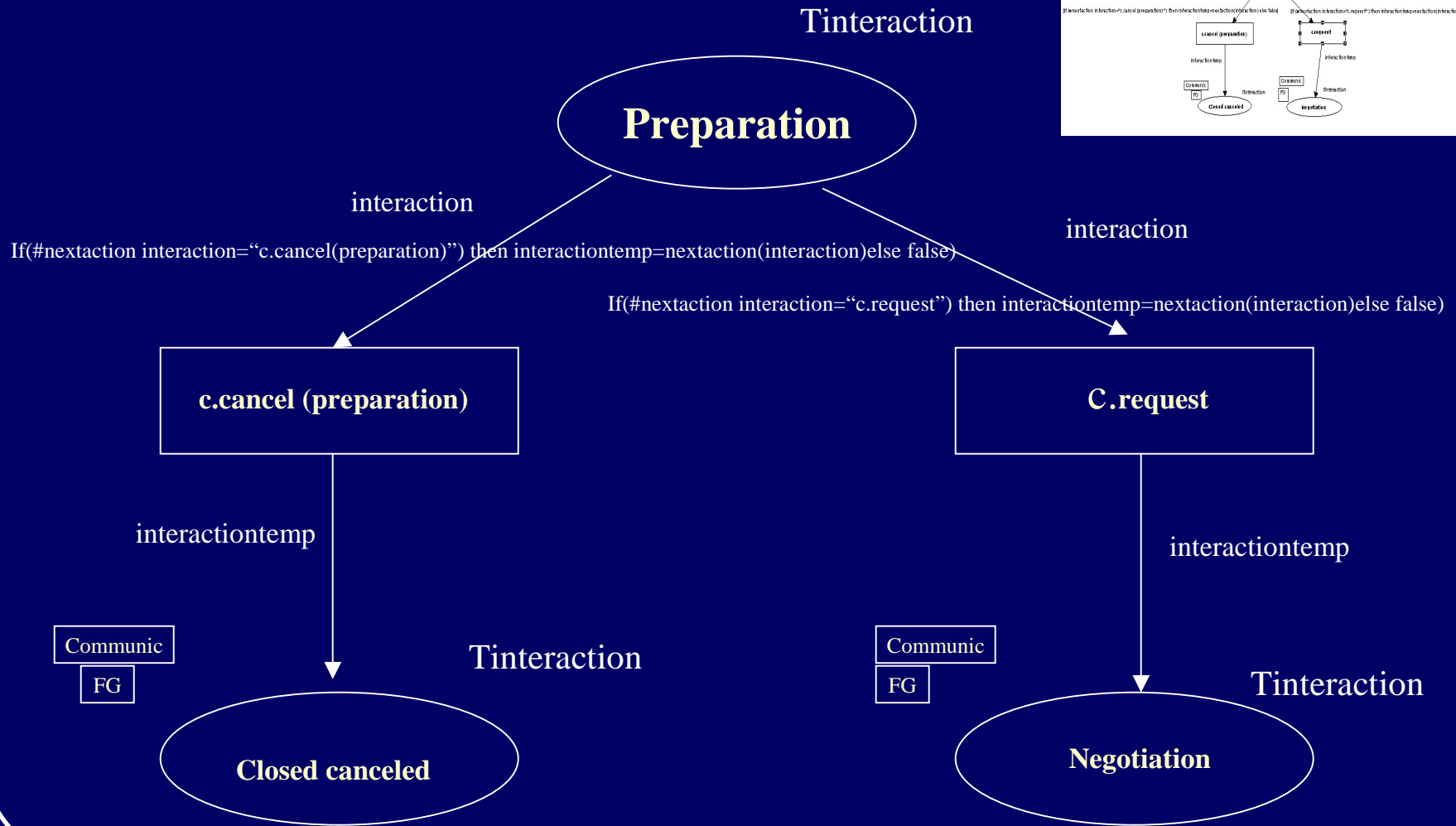

# Negotiation Step

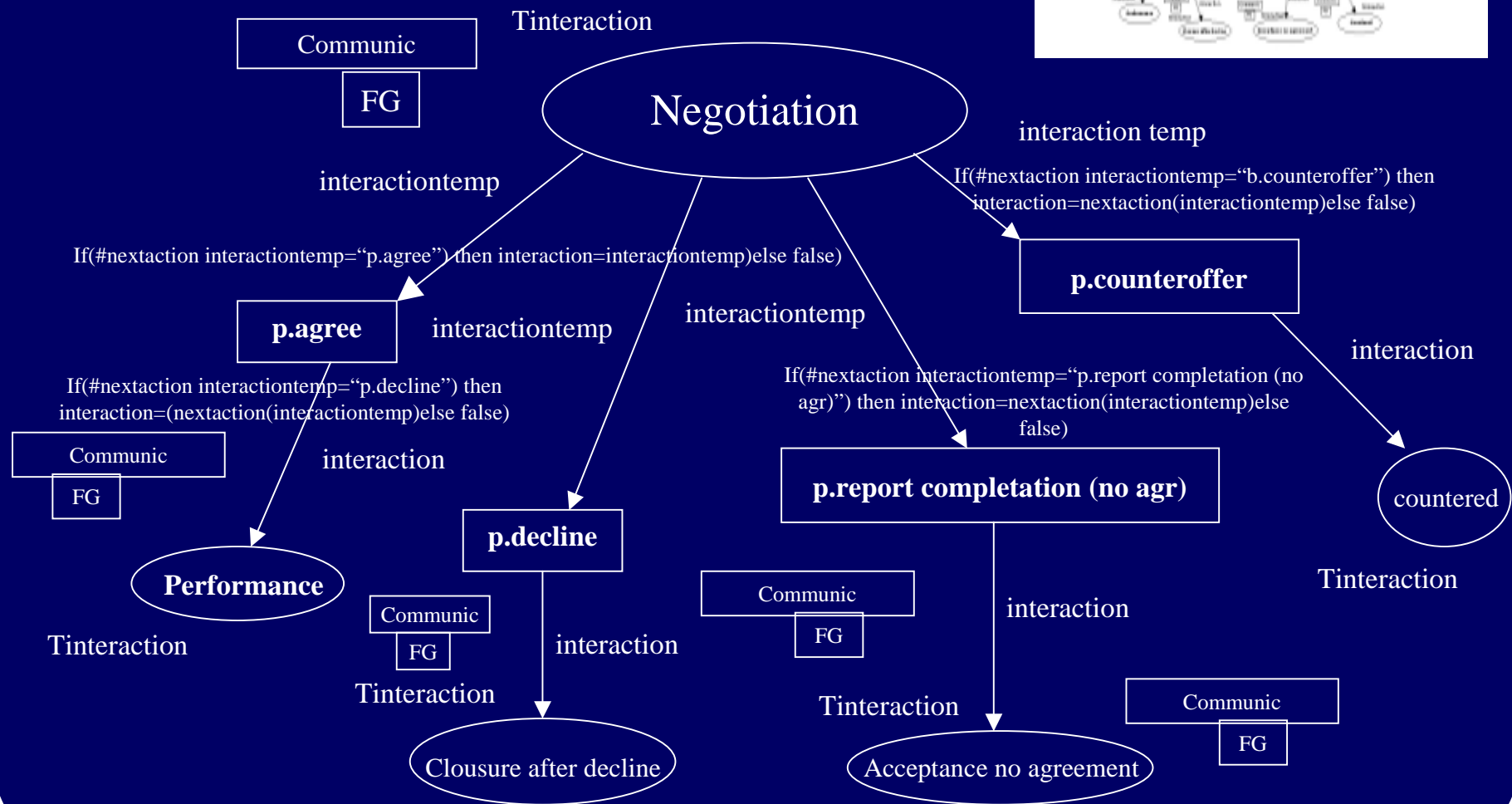

# Specifying the Systems Messages Using CPN

- interaction 1 = ((Buyer 1), Marketplace, (Supplier 1, Supplier 2, ... , Supplier n), Product 1, Marketplace.Report Completion))
- interaction 2 = ((Buyer 2), Marketplace, (Supplier 1, Supplier 2, ... , Supplier m), Product 2, Marketplace.Agree))

# Conclusion

- The use of CPN is:
  - easy to model the state of the interactions.
  - easy to model the behaviour of the interactions.
  - easy to represent different messages at a time.
  - able to simulate the system interaction dynamics.

# Conclusion

- The IMCIS methodology integrates mainly:
  - The action basic loop.
  - The use of CPN for the interaction modelling.
  - The communicative acts of FIPA.

# Future Work

- To incorporate to the model temporal and fuzzy aspects.
- To incorporate the intentional model in order to handle modal temporal aspects.



<http://www.itesm.mx>

# An Expressive Coloured Petri Nets Methodology Applied to a Business to Business Environment

Fernando Ramos ([framos@campus.mor.itesm.mx](mailto:framos@campus.mor.itesm.mx))

Juan Frausto ([jfrausto@campus.mor.itesm.mx](mailto:jfrausto@campus.mor.itesm.mx))

Francisco Camargo ([fcamargo@campus.cem.itesm.mx](mailto:fcamargo@campus.cem.itesm.mx))

MOCA'01, Workshop on Modelling of Objects, Components, and Agents,  
August 28, 2001